

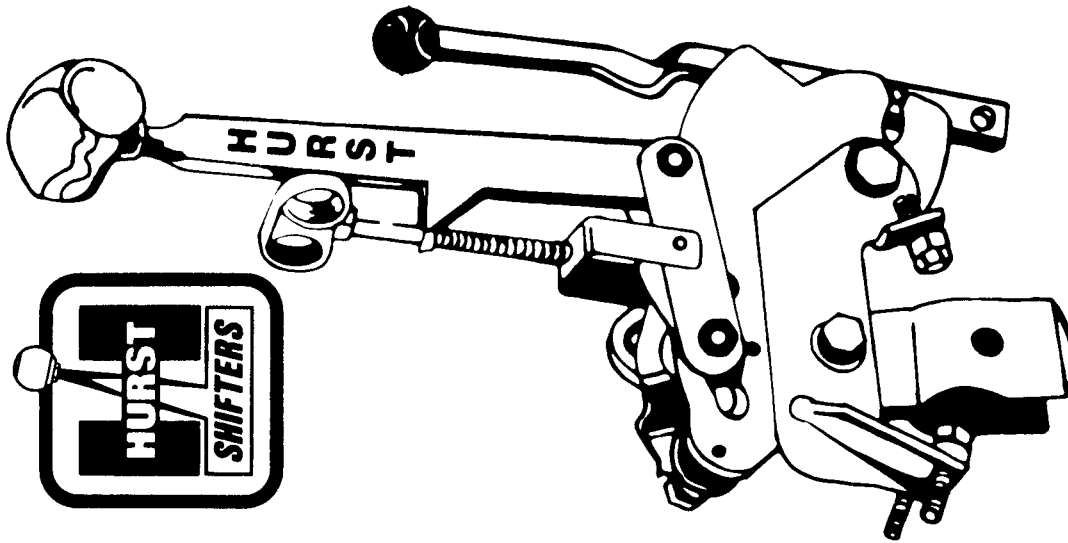

# V-GATE 2 4-SPEED SHIFTER #3738175

1970-73 MUSTANG (10 BOLT TOP COVER)  
390, 428, 429 CU. IN. ENGINE



## V-GATE 2 SHIFT PATTERN

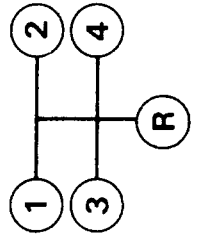

### LIMITED WARRANTY

Hurst Shifter warrants the products in this catalog only to the original purchaser at retail to be free from defective materials and workmanship for a period of ninety (90) days from the date of original retail purchase.

HURST SHIFTER MAKES NO EXPRESS WARRANTY AS TO THIS PRODUCT OTHER THAN THE LIMITED WARRANTY STATED HEREIN. THERE ARE NO WARRANTIES WHICH EXTEND BEYOND THE EXPRESS TERMS OF THIS LIMITED WARRANTY. HURST SHIFTER MAKES NO IMPLIED WARRANTIES WHATSOEVER, INCLUDING THE IMPLIED WARRANTY OF MERCHANTABILITY AND THE IMPLIED WARRANTY OF FITNESS FOR A PARTICULAR PURPOSE. HURST SHIFTER SHALL NOT BE LIABLE FOR ANY INCIDENTAL DAMAGES, INCLUDING THE COST OF INSPECTION, RECEIPT, TRANSPORTATION, CARE OR CUSTODY OF THIS PRODUCT, AND FOR ANY CONSEQUENTIAL DAMAGES, INCLUDING DELAY, LOSS OF INCOME OR PROFITS, OR INJURY TO PERSON OR PROPERTY, ARISING FROM ANY ACTUAL OR ALLEGED BREACH OF THIS LIMITED WARRANTY.

Some states do not allow the exclusion or limitation of incidental or consequential damages or limitations on implied warranties, so these limitations or exclusions may not apply to you. This warranty gives you specific legal rights, and you may also have other rights which vary from state to state.

Materials, components, specifications, colors, model changes, availability and prices are subject to change without notice or obligation.

Manufacturers' brand names, trademarks and registered trademarks are used for reference only, and are not to imply that any product is of their manufacture or any association therewith.

Hurst Shifter makes no representation or warranty that its products comply with local, State or Federal emission levels, noise levels or safety standards. The purchaser assumes all responsibility for such use and compliance.

### CONSUMER SERVICE

A highly trained Consumer Service Department is maintained by Hurst Shifter to answer your technical questions, provide additional product information and offer various recommendations. See your local retailer of Hurst products for specific prices.

For best results, Consumer Service calls, correspondence and warranty questions should be directed to the following address:

HURST SHIFTER  
8700 Brookpark Rd.  
Cleveland, Ohio 44129-6899  
Phone: (216) 398-8300  
(9:30 a.m. — 5:00 p.m. EST)

# NOTE: READ INSTRUCTIONS CAREFULLY

**WARNING:** The wheels must be blocked securely to eliminate any possibility of vehicle movement during installation. If car is raised for ease of installation, make sure to use quality jack stands or ramps of equal height at all four corners. Above all, make certain vehicle will not move or fall off supporting devices during installation. Do not remove transmission. **NOTE:** It is necessary to modify floor pan to accommodate shifter.

1. This shifter was designed for Competition use only. Floor pan must be modified to accommodate the unit.
2. Check all part numbers and part numbers in kit with part numbers listed on instruction sheet parts list.
3. Install adapter plate on tailshaft housing as shown in **Detail A**, using Hex-head cap screws and washers. Tighten securely.
4. Place spacers between shifter and adapter plate. Install shifter on adapter plate using 1/2" bolts and lockwashers supplied. Tighten securely.
5. Insert neutral alignment shaft.
6. There are two sizes of steel bushings in the parts kit. Lubricate the larger bushings with a lightweight grease and insert into the transmission arms as shown in **Detail A**. Fasten the rods to the arms with spring clips.
7. Thread the rod pivots part way onto rods. Install the arms and rods on the transmission using the existing nuts, washers and lockwashers. Check **Detail A** for correct positioning of arms and rods.
8. Rotate both transmission arms to neutral position. Lubricate the pivot bushings (smaller bushings) with a lightweight grease, and insert bushings into the shifting forks, check **Detail A**. Thread the rod pivots up or down the rods until they slip into the pivot bushings in the shifting forks. Insert spring clips.
9. Adjust reverse pivot to a position where the pin in the reverse lever is just clear of the reverse lock slot, check **Detail B**. Insert pivot into lever with no bushing. Remove neutral alignment shaft.
10. Check alignment by shifting through the pattern. If the adjustment is not satisfactory, re-adjust one or more rod pivots until desired action is attained. Grasping the T-handle, pull up on trigger mechanism and shift forward into 1st gear. Release trigger and shift straight back into 2nd, straight forward into 3rd, and again straight back into 4th. Reverse can only be engaged when shifter is in neutral position. When in reverse, shifter is locked. **To avoid damage, do not try to shift into any other gear when reverse is engaged. To down shift, just reverse the pattern.**

**Lubrication** - Every 3,000 - 5,000 miles lubricate all moving parts including the rod and pivot bushings.

<b>A</b> ADAPTER PLATE	1959044
<b>B</b> SPACERS	1951059
<b>C</b> ROD, 1st - 2nd	2136118
<b>D</b> ROD, 3rd - 4th	2136110
<b>E</b> ROD, Reverse	2136126
<b>F</b> ARM, 1st - 2nd	1058038
<b>G</b> ARM, 3rd - 4th	1058032
<b>H</b> ARM, Reverse	1058000
<b>I</b> BUSHING, ARM	
<b>J</b> BUSHING, PIVOT	
<b>K</b> SPRING CLIP	
<b>L</b> ROD PIVOT	97X91055
<b>M</b> ROD PIVOT	97X91052
<b>N</b> HEX BOLT 1/2"-13 x 1 3/4	
<b>O</b> HEX BOLT 5/16"-18 x 1 1/4 N.C.	
<b>P</b> HEX BOLT 1/2" - 13 x 1 3/4	
<b>Q</b> LOCKWASHER 1/2"	
<b>R</b> LOCKWASHER 5/16"	
V-GATE 2, PIT PACK	3321657

**DETAIL A**

**NEUTRAL ALIGNMENT SHAFT**  
Part No. 95008

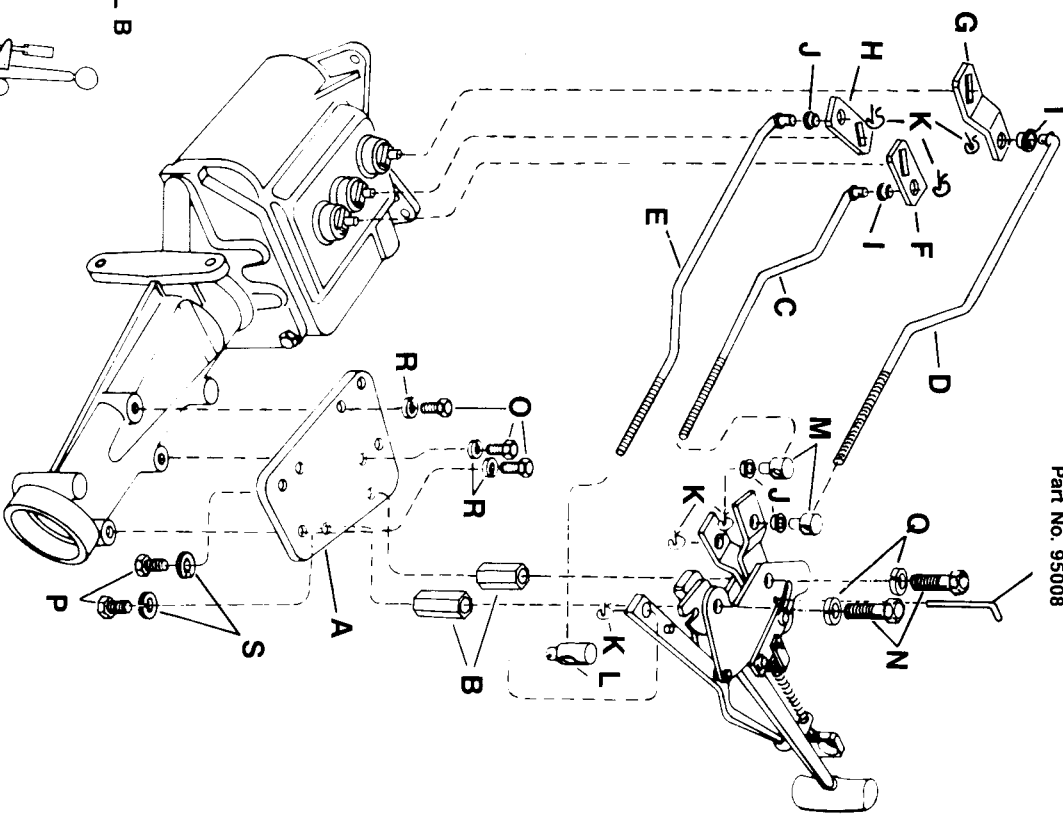

**DETAIL B**

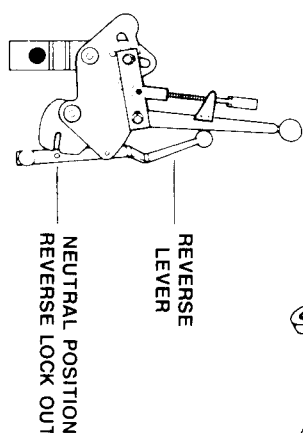

**#3738175**